

Improved PFC Boost Choke using a Quasi-Planar Winding Configuration

Dave Shonts
Schott Corporation
1000 Parkers Lake Road
Wayzata, MN 55391

Abstract- A novel approach to boost inductor design using a quasi-planar winding configuration consisting of a helical wound flat copper coil to develop high ampere-turn capability for use in high current power factor correction boost circuits is presented. By comparing this approach with four other commonly used boost choke configurations, the advantage of this approach is demonstrated.

I. INTRODUCTION

As the requirement for power factor correction (PFC) has become more widespread due to such international regulations as IEC1000-3-2 which limit input line current harmonics, the PFC boost converter has become a necessary part of most power supplies intended for international use.

Active PFC boost converters can be divided into two types: the continuous conduction mode fixed frequency type and the discontinuous conduction mode variable frequency (constant on-time) type. The continuous conduction mode type (CCM) requires a very fast output rectifier with good forward and reverse recovery times since the diode must switch from zero to full current in tenths of microseconds.

The CCM PFC and the discontinuous conduction mode (DCM) PFC both require a boost choke that can withstand high voltage (typically 400V) square waves which necessitates the selection of a core material with low core loss at high flux levels and high frequency (typically from 20kHz to 500kHz).

There is a big difference in the current ripple requirement between the two approaches: the DCM PFC boost choke has much higher ripple current levels at the same output power level. This is because it must switch from zero to line current levels each PWM cycle unlike the CCM PFC boost choke which does not have its current drop to zero on each cycle.

The DCM PFC requires a very high quality boost inductor since it must switch extremely high peak ripple currents and voltages at a wide variation of

frequencies. Core manufacturers have developed some useful materials over the last decade which have proved useful in the construction of high frequency boost inductors. Some examples of these materials for cores are Mag Inc.'s Kool Mu available in toroidal cores and high frequency gapped ferrite available in ETD cores. But a good winding configuration has not been available: round wire does not meet the needs of high frequency; foil wound inductors are better as far as skin effect is concerned but trap heat in the inner windings, litz wire is hard to terminate and also traps heat in the inner windings especially around the location of the center leg gap.

This paper introduces a new approach for boost inductor windings: the Helical Wound Technology (HWT) which is a helical wound flat copper coil with a baked on thermal epoxy insulation. This new configuration allows the construction of a boost choke with flat copper helical windings which are perpendicular to the center leg of the ferrite ETD core. Each winding has an outer surface which allows internally generated heat to escape to the surface. The winding does not require a bobbin since it is a self supporting structure which allows a larger portion of the window area to be used for copper. Since the foil winding is typically 20 mils thick or more it is a self-leaded device which lends itself to easy pc mount on through hole boards (see Figure 1). A detailed analysis of this new component is made using a CCM PFC test circuit which allows the variation of frequency from 20kHz to 200kHz and load from 100Watts to 10kWatts (see Fig. 2). This circuit along with the PFC CCM control circuit (see Fig. 3) allows the test and measurement of all the critical

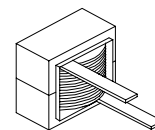

Figure 1. A new type of boost choke construction: gapped ETD ferrite with the new helical wound technology (HWT)

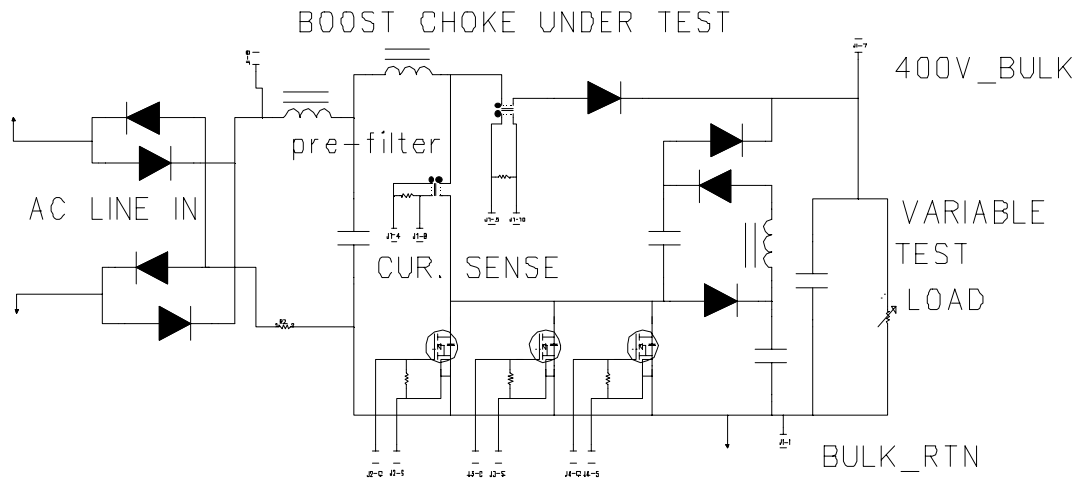

Figure 2. Continuous Conduction Mode PFC Test circuit

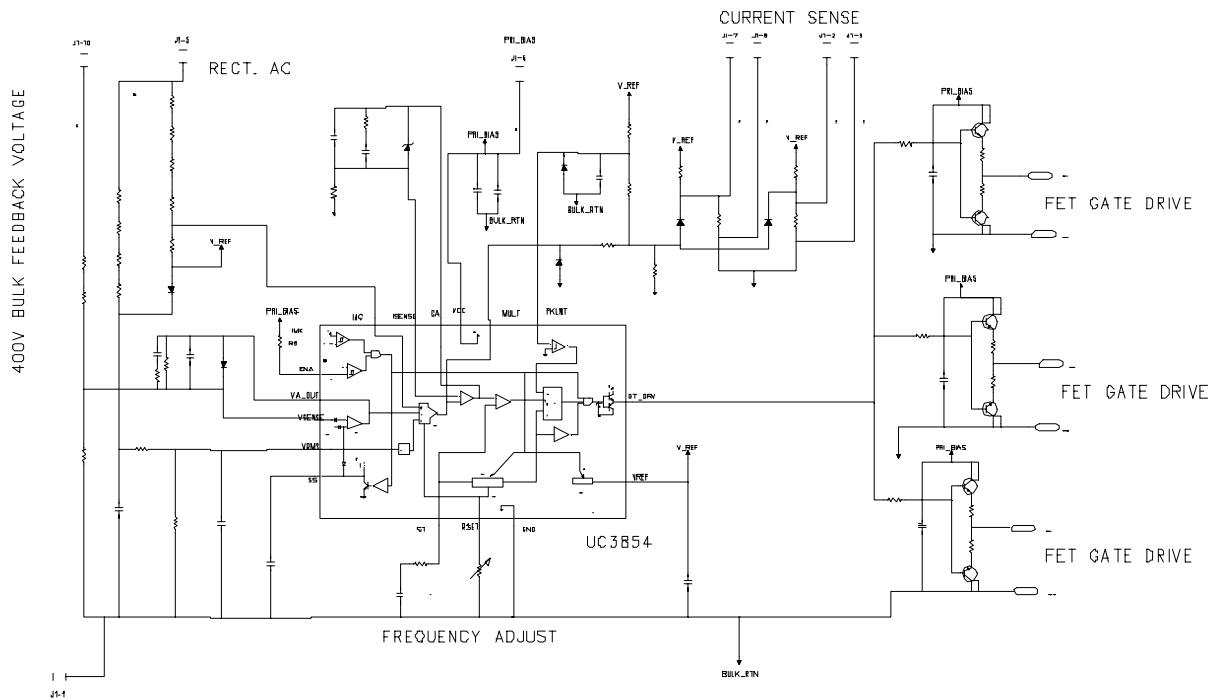

Fig. 3. Continuous Conduction Mode PFC Control Circuit

parameters associated with the boost choke performance such as 1) boost inductor winding temperature versus frequency (measured at the internal hot spot of the winding 2) boost inductor winding temperature as a function of current and 3) boost inductor winding temperature as a function of input to output voltage. These temperature measurements were made with an isolated thermal sensor placed in the inner winding of the boost choke under test. By measuring the temperature at which the inductor reaches 100 degrees Centigrade, a quantifiable limit to the to the inductors current carrying capacity at a given frequency and input voltage can be found. It is worthy to note that the CCM PFC circuit was chosen for the empirical test vehicle because it allows the precise adjustment of its fixed frequency where as the DCM PFC circuit typically sweeps out a wide range of frequencies as a function of line and load. By adjusting the load and frequency on the CCM PFC it is possible to simulate the ripple current , DC bias current, and voltage that the boost inductor in the DCM PFC (also called the transition mode PFC or constant on-time PFC). The power loss variations between different boost chokes can be measured by noting the difference in efficiency of the converter with each type of boost choke inserted into the test circuit. It is essential that an extremely robust test circuit be used in order not to have efficiency variations masked by other elements in the convertor. The test circuit shown in Fig.1 and 2 used large Isotop packaged fet's and diodes that were heatsinked to a large baseplate, which eliminated the variation in RDS (ON) and diode conduction and switching losses during the testing of each individual boost choke.

II. COMPARISON WITH 4 OTHER BOOST . CHOKE WINDING CONFIGURATIONS

In addition to the empirical measurements made on the boost choke, it and four other winding configurations were analyzed on "Proxy, A Proximity and Skin Effect Analyzer" (ref.1) . This program provides an AC loss analysis of different winding configurations. It analyzes planar, litz, foil and round wire winding configurations using Fourier analysis. This program allows the input of the DC bias current and the triangular waveform current. It uses the DC bias current to determine the minimum loss condition, and uses the ripple current content to calculate the minimum loss for a given winding thickness. It allows the determination of the optimum winding configuration to reduce the ratio of AC to DC loss.

The 5 different boost choke configurations analyzed:

- 1) toroidal core with Litz wire (Mag. Incs. Kool Mu toroid, 77109-A7 with 420 strands of AWG 36 Litz wire)
- 2) copper foil wound on an ETD49-3C85 core (Phillips largest ETD core and bobbin conventionally wound with 10 mil copper foil and tape.
- 3) ETD49-3C85 core and bobbin wound with 420 strands of AWG36 Litz wire
- 4) Toroid core with conventional wire (Mag. Incs. Kool Mu toroid 77109-A7 with Awg 12 wire)
- 5) Improved PFC Boost Choke using a Quasi-Planar Winding Configuration consists of a 20 mil thick by .225 inches wide helical wound copper coil with an I.D. of .925 inches , an O.D. of 1.15 inches wound coated with 3M thermal epoxy as interwinding insulation. There are 44 spiral turns on an ETD49-3C85 core.

For the purposes of the analysis each of the inductors were designed for 80uH with 10A of DC bias current. As can be seen from Figure 4 and Figure 5 there are large differences in DCR, copper weight per window area and skin depths between the various winding configurations. In order to achieve a low loss boost inductor it is essential that 1) DC loss is low 2) AC loss ratio is low and 3) core loss is low. In addition to this the ideal winding configuration would have a means for allowing any heat generated to radiate out freely from the center and not trap heat in the areas around the gap . The inductor temperatures were all measured at ambient air temperatures (25C) and the inductors were not tied to a base plate or heatsink The temperatures of the inductors were measured at 500 watts of output power into a resistive load ,and the input voltage at 110VAC.

III. RESULTS

As can be seen from Fig. 6 and 7 the HWT inductor measured the lowest temperatures and the highest efficiency of the inductors tested. By adjusting the frequency, load, and input voltage the test circuit allows the adjustment of the AC ripple magnitude as well as the DC bias level to any value desired. It is in this way that the conditions the boost choke would see operating in a DCM PFC or Transition Mode PFC can also be simulated

Comparison of Winding methods

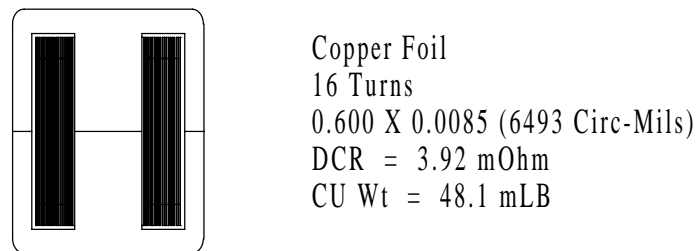
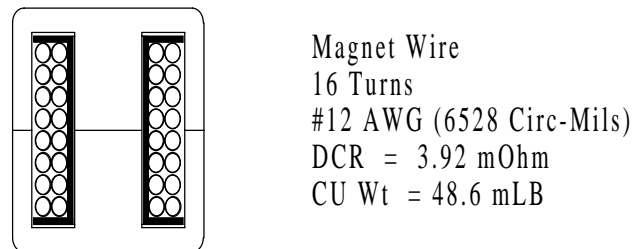
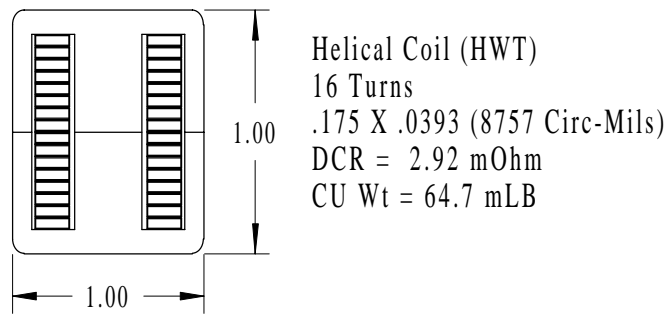

Figure 4. Comparison of winding methods via a normalized one inch by one inch winding cross section

SKIN EFFECT EXAMPLE

FREQUENCY = 200 kHz

TEMPERATURE = 100 °C

SKIN DEPTH = 6.7 MILS









	SIZE MILS	TOTAL X-SECT CIRC-MILS	SKIN X-SECT CIRC-MILS	% UTILIZATION	% vs ROUND
	RECT 130 X 40	6621	2661	40.2%	133.5%
	SQUARE 72.11	6621	2223	33.6%	111.5%
	RND Ø 81.37	6621	1993	30.1%	100.0%
	RECT 130 X 24	3973	2389	60.1%	158.9%
	SQUARE 55.86	3973	1671	42.1%	111.1%
	RND Ø 63.03	3973	1503	37.8%	100.0%
	RECT 200 X 19	4838	3493	72.2%	208.2%
	SQUARE 61.64	4838	1867	38.6%	111.3%
	RND Ø 69.56	4838	1678	34.7%	100.0%

FIGURE 5. Skin Effect Comparisons



NOTE :

- ⊕ QUASI-PLANAR WOUND BOOST CHOKE (HWT TECHNOLOGY)
- 77109-A7 KOOL MU TOROID WITH LITZ WIRE
- ⊖ CONVENTIONAL COPPER FOIL ON ETD49-3C85 CORE AND BOBBIN
- ◇ ETD49-3C85 CORE AND BOBBIN WOUND WITH LITZ WIRE
- ⊞ KOOL MU TOROIDAL CORE 77109-A7 WITH AWG 12 WIRE

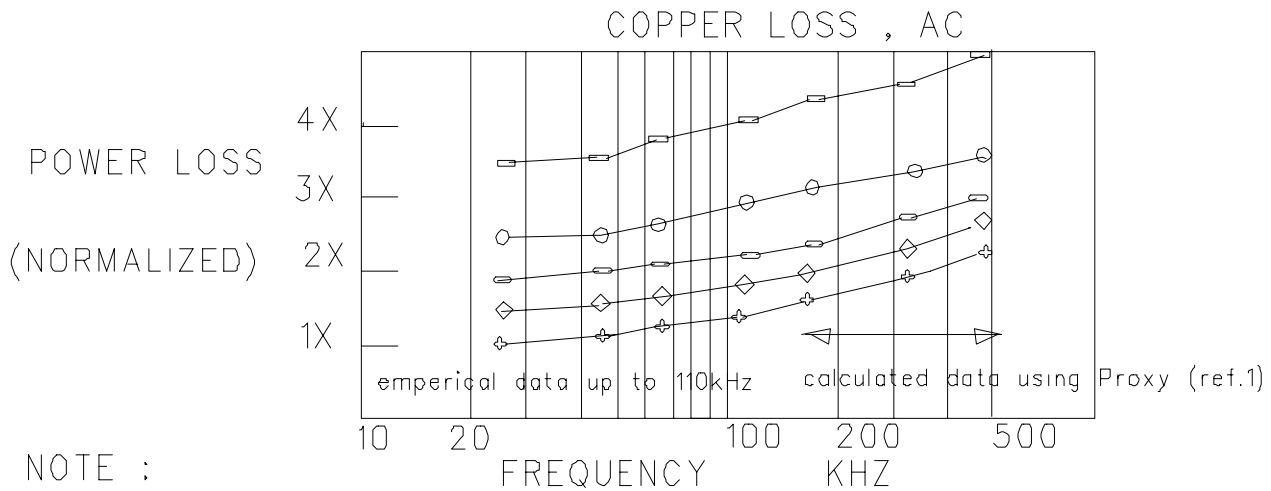

Figure 6. Normalized power loss

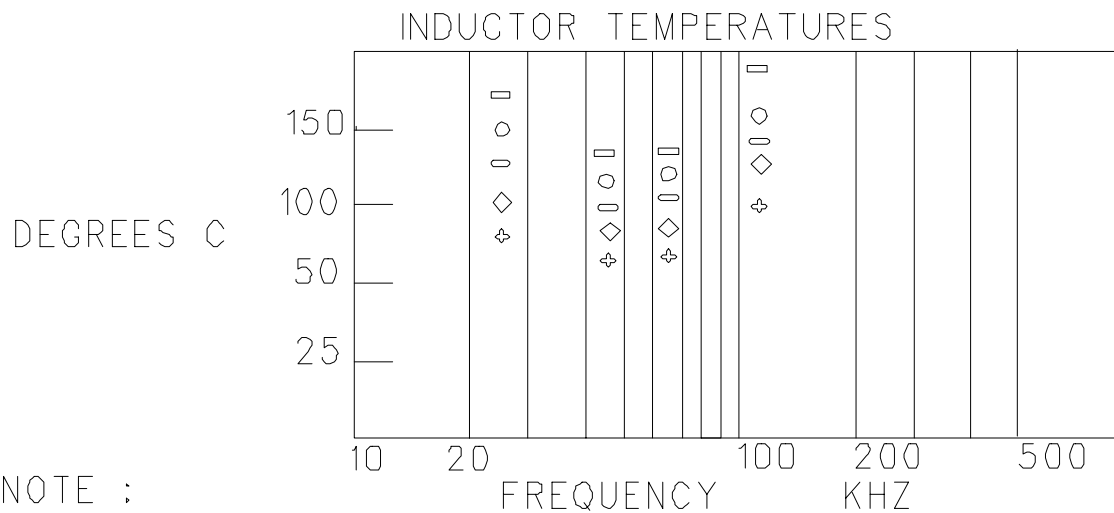

NOTE :

- ⊕ QUASI-PLANAR WOUND BOOST CHOKE (HWT TECHNOLOGY)
- 77109-A7 KOOL MU TOROID WITH LITZ WIRE
- ⊖ CONVENTIONAL COPPER FOIL ON ETD49-3C85 CORE AND BOBBIN
- ◇ ETD49-3C85 CORE AND BOBBIN WOUND WITH LITZ WIRE
- ⊞ KOOL MU TOROIDAL CORE 77109-A7 WITH AWG 12 WIRE

Figure 7. Empirical measurements of boost choke temperatures

IV. SUMMARY

In this paper we have looked at a new winding configuration for boost chokes and made comparisons to other typical methods of the past. This paper has shown that the HWT configuration is capable of producing the lowest DCR per unit volume which relates to the lowest minimal winding loss at DC bias currents.

We have also found that its AC loss ratio is very low in comparison to the other winding structures because of its quasi-planar winding structure. These characteristics have explained the low temperature readings under comparable conditions of the HWT Quasi-planar boost choke in comparison with the other designs.

V. CONCLUSION

A novel approach to boost inductor design using a spiral wound flat copper coil shows great promise in meeting the needs of the power supply designer:

- 1) a printed circuit mountable inductor that is self leaded
- 2) an inductor utilizing a flat, thin conductor which accommodates 10 mil skin depth requirements, making for low ac losses in the conductor at frequencies from 10kHz to 500kHz.
- 3) A spiral or helical wound coil which lends itself to either planar, low profile inductors, or quasi-planar coils mounted on ETD type cores yielding a very high ampere turn per linear cm. capability in a very dense package.
- 4) This new coil structure leads to an inductor with 50% higher energy storage capability than the other approaches analyzed (in other words, higher inductance at a higher current in a given space).
- 5) This new coil structure leads to an inductor with significantly lower copper losses than those wound using traditional methods.
- 6) As magnetic core manufacturers continue to improve inductor cores to operate at higher frequencies it is also important to look at new coil winding techniques such as this one for high ampere turn capability.

ACKNOWLEDGMENT

I would like to thank Tom Cochran of Schott Corp for the comparison data of the different winding techniques (Figs. 4 and 5) and for his help in the design and obtaining of materials for the various boost chokes.

REFERENCE

- [1] "Proxy" A Proximity and Skin Effect Analyzer by KO SYSTEMS , David O'mear 10437 Laramie Ave, Chatsworth ,Ca 91311